

# HR 180

“CP version”



The **HR 180** is one of our most sold models because of its versatility and adaptability to many different applications such as:

- Drilling with augers or buckets
- Execution of drilling casings directly with rotary and by casing oscillator
- Continuous Flight Auger (CFA)
- Diaphragm Walls
- Execution of Double Head drilling

The **HR 180** is available in two versions:

**HR 180 CP** – the standard version is equipped with a pull-down cylinder which applies its force on the rotary and allows a rotary stroke of 5.100 mm (17 ft) approx. It is mainly used for drilling large diameter bore holes. The HR 180 CP uses a parallelogram system of articulation.

**HR 180 THD** – available upon request, the THD system moves the rotary by utilizing the winch, allowing the rotary a longer stroke along the mast, 10.000 mm (33 ft) approx. The THD version is particularly useful for driving and extracting casing tubes directly by the rotary and, without a doubt, increasing your daily productivity.

The HR 180 drilling rig base is already predisposed for all the various works listed above.

### Working Characteristics

#### Works with Augers & Buckets:

Max diameter with casing	1.600 mm	5.2 ft
Without lower mast extension	2.000 mm	6.5 ft
Depths	30 - 40 - 50 - 60 m	98.5 - 131 -164 - 197 ft

#### Casing Oscillator:

Max. diameter	1.600 mm	5.2 ft
---------------	----------	--------

#### Works with CFA:

Max diameter	1.200 mm	4 ft
Depths	19 + 5 m	62 + 16 ft

#### Diaphragm Walling:

Max size	1.000 x 3.000 mm	3.3 x 9.5 ft
Depths	32 m	105 ft

#### Jet Grouting

Max depth	32 m	105 ft
-----------	------	--------



# CP version

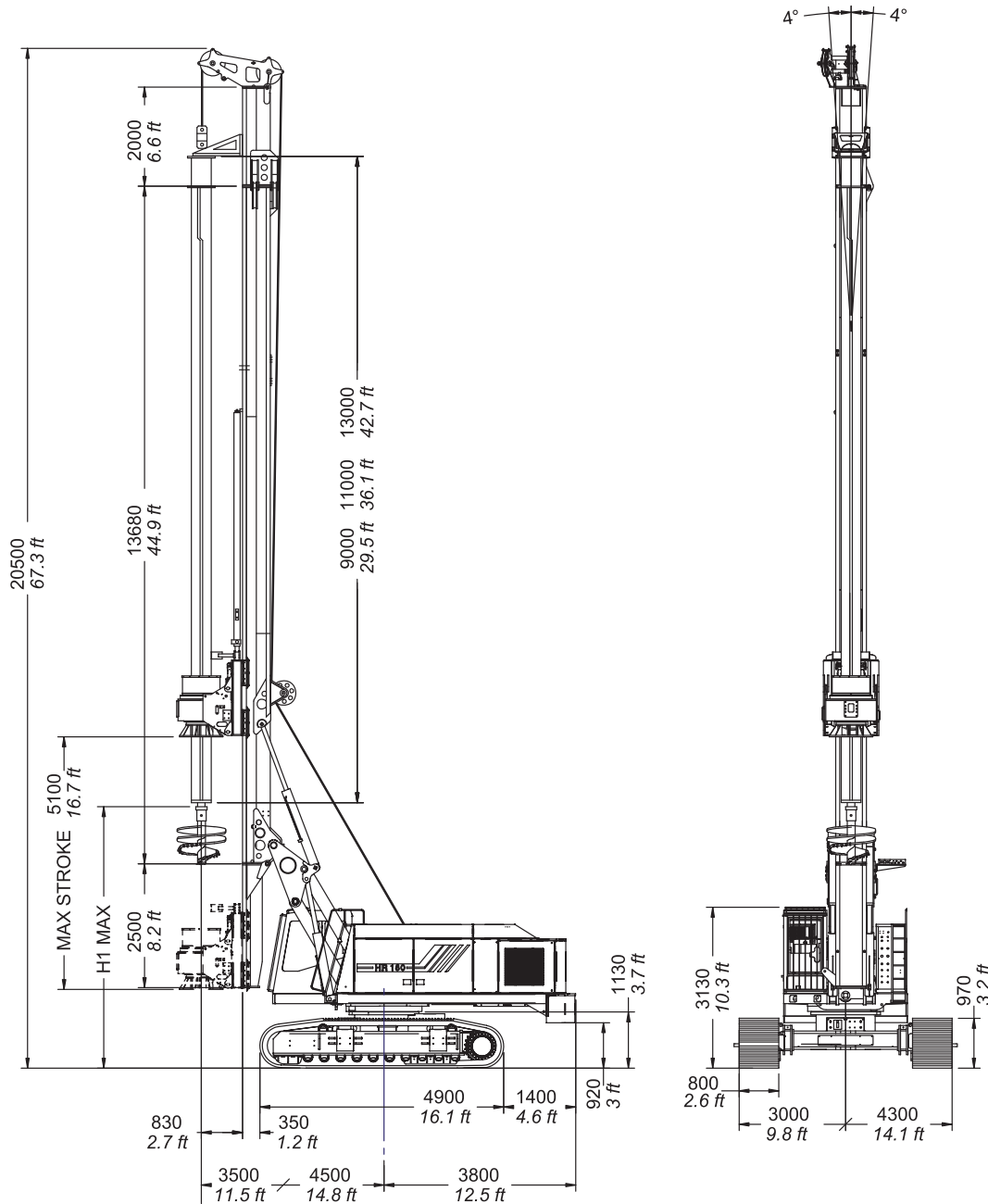

## Technical Data

### Rotary:

Nominal torque	233 KNm	171,900 lbsft
Rotary nominal pulldown	180 KN	40,500 lbs
Unloading speed	150 rpm	
Rotary stroke	5.100 mm	16.7 ft

### Winches:

Main winch nominal pullback	180 / 230** KN	40,500 / 51,750** lbs
Auxiliary winch nominal pullback	80 KN	18,000 lbs

### Diesel Engine:

#### CATERPILLAR C9 ACERT

Power	242 KW	325 HP
Hydraulic oil tank	800 liters	211 gal
Fuel Tank	430 liters	114 gal

### Expandable Crawlers:

Length	4.900 mm	16.1 ft
Width	3.000 - 4.300 mm	9.8 ft - 14.1 ft
Shoes	800 mm	2.6 ft

<b>Approx. Weight:</b>	57 - 60 tons	128,600 - 132,500 lbs
------------------------	--------------	-----------------------

\*\* on request

03/2013 All technical data are to be considered as approximate. MAT reserves the right to modify them opportunistically. All numbers shown in feet and inches have been rounded and are approximate for the simplification of conversion. The nominal values are referred to 100% total efficiency.

**MAT S.p.A. DRILLING RIGS**  
 via Flaminia Seconda, 149/153 - P.O. Box 1040 60027 OSIMO (AN) ITALY  
 - TEL +39 071 7822186 - FAX +39 071 780535  
 - web: <http://www.mat.it> - E-mail: [info@mat.it](mailto:info@mat.it)

